

F8111 Assembly & Care Guide

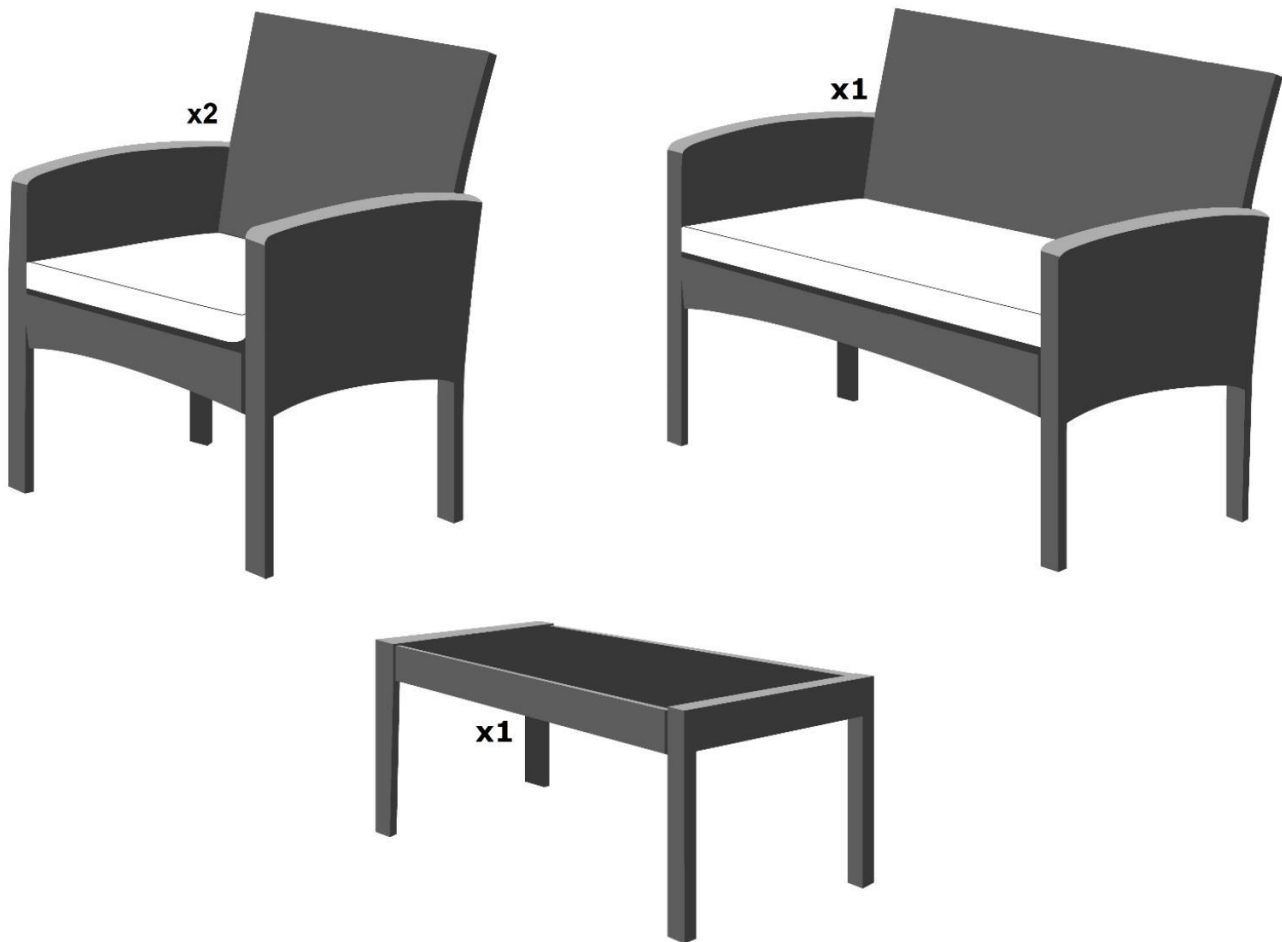

If you have any questions regarding this product, please contact info@jjinternationalinc.com so we can assist you.

Care Guide for Outdoor Cushions

You're going to love your outdoor cushions. They instantly brighten your outdoor space and keep you cozy for hours of primetime lounging. With a few easy preventive measures, you can keep your cushions in tip-top shape season after season. Here are our most helpful tips for extending their life.

For the Longest Life with the Least Amount of Cleaning:

Bring your cushions inside or move to a protected area when not in use
Use outdoor furniture covers if you intend to leave them outside

If You Are Going to Leave Your Cushions Out & Unprotected:

Tip and angle your cushions on the seat after use
Bring your cushions under cover before it rains

Cushions used under trees should be kept free of natural debris -- the biggest culprit for mildew
IMPORTANT... In order to prevent mildew build-up please store cushions inside during the cold winter months or wet weather

Allow at least 24 hours for wet cushions to dry (never use a hairdryer or steamer on your cushions or put them in the dryer)

Make Cleaning your Cushions Easy

Do you dread cleaning outdoor furniture as much as we do? Here's the good news: you can prevent or at least delay having to deep clean your cushions with these tried-and-true methods:

Wipe off your cushions with damp cloth as needed to remove dirt and debris

Brush off dirt and wipe up spills immediately to avoid embedded stains

Spray on a cleaning solution of water and mild soap

Use a soft bristle brush to clean

Allow cleaning solution to soak into the fabric

Rinse thoroughly until all soap residue is removed and always air dry for at least 24 hours

Re-treat fabrics regularly throughout the season (303 High Tech Fabric Guard™ recommended)

If you have to wash, first close all zippers. Machine wash in cold water on the delicate/handwash cycle with normal amounts of mild laundry detergent. Allow fabric to air dry. Make sure to re-treat fabric after this type of deep clean.



If you have any questions regarding this product, please contact info@jinternationalinc.com so we can assist you.

WARNING! Upon completion of assembly, please inspect that all parts are attached and assembled properly. Confirm plastic leveling feet and/or foot protectors are installed.

If you have any questions regarding this product, please contact info@jjinternationalinc.com so we can assist you.

1-Year Limited Warranty Program

For a period of one (1) year after date of purchase, the Manufacturer will either repair or replace defective components in accordance with this Limited Warranty. This warranty is between the Manufacturer and the original purchaser and is valid only when accompanied by the original purchaser's sales receipt showing original date of purchase and location of purchase. Replacements under this warranty revert back to the date of original purchase for future warranty.

The Manufacturer or its authorized dealer can accept or reject warranty claims based on its findings. This warranty applies in normal residential use only and is not intended for commercial use. The Manufacturer can make substitutions as required of materials, components, and subcomponents of comparable value and utility. This warranty is limited to product repair or replacement (to be determined solely by the Manufacturer). Warranty return is limited to only the single affected component.

This limited warranty covers only manufacturing defects and does not cover normal wear and tear, damage due to acts of nature (such as, but not limited to freezing or high winds), abuse or misuse, including chemical damage from suntan oil or other chemicals, exposure to extreme heat or cold, abrasion or excessive weight. This product is intended to be used in standard installations only. This warranty is void if the product is not used for its intended purpose. The Manufacturer disclaims liability for any aspect of installation and any inconvenience caused by a defective part of a component.

Certain items are not covered by this warranty. These include, but are not limited to the following:

1. Components subjected to abuse, including abuse intended to simulate failure.
2. Damages caused by retailer, shipper or installation crew (such as scratches, dents, tears, chips, etc.).
3. Any part which merely exhibits normal wear yet functions essentially as new, including chips, scratches or stretching of materials and stitching.
4. Tears, punctures, scratches or any damage caused by improper installation or use.
5. Damage to frames/welds resulting from improper assembly or exposure to water and/or sub-freezing temperatures is not covered. General frame rusting is not covered.
6. Fading and/or discoloration of fabrics/cushions/straps/wicker resulting from exposure to the elements, chemicals, oils, fluids or any other cause are not covered.

To make a claim, send a request to the email address below. Please have available a copy of the original sales receipt along with a brief description of the problem. Please also provide your email address and daytime telephone or cell phone number. All items may be charged actual freight costs plus \$15 for handling. Repairs or replacement will be made at the Manufacturer's option. Sales and use taxes, plus shipping and handling charges are the responsibility of the consumer.

THIS IS THE ENTIRE EXCLUSIVE EXPRESS LIMITED LIABILITY. THE MANUFACTURER NEITHER MAKES NOR IS RESPONSIBLE FOR ANY OTHER WARRANTIES, EITHER EXPRESS OR IMPLIED, INCLUDING THOSE OF RETAILING DEALERS. THIS EXCLUSIVE REMEDY IS LIMITED TO RECEIPT OF A CREDIT IN CONNECTION WITH THE REPAIR OR REPLACEMENT OF ANY PRODUCT OR COMPONENT DEEMED TO BE DEFECTIVE UNDER THE TERMS AND CONDITIONS AS STATED IN THIS WARRANTY. NEITHER THE PRODUCT MANUFACTURER NOR ITS AGENTS SHALL BE LIABLE IN ANY CASE FOR INCIDENTAL, INDIRECT, SPECIAL OR CONSEQUENTIAL DAMAGES RESULTING FROM THE USE OF THIS PRODUCT OR ARISING OUT OF ANY BREACH OF THIS WARRANTY OR NEGLIGENCE EVEN IF IT HAS BEEN ADVISED OF THE POSSIBILITY OF SUCH DAMAGES. EXCEPT AS OTHERWISE MAY BE REQUIRED BY LAW, THERE ARE NO OTHER EXPRESS OR IMPLIED WARRANTIES OTHER THAN THE WARRANTY DESCRIBED HEREIN, AND ALL OTHER WARRANTIES, INCLUDING ANY IMPLIED WARRANTY OF MERCHANTABILITY OR FITNESS FOR A PARTICULAR PURPOSE ARE EXPRESSLY DISCLAIMED.

If you have any questions regarding this product, please contact info@jjinternationalinc.com so we can assist you.

Parts

Check and make sure you get the components on the list, contact us for any missing

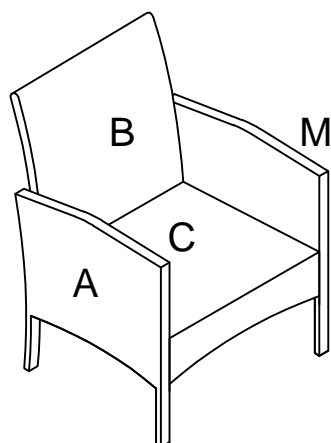

■ 2-Single Rattan Chair

A:Rattan Chair Right Armrest



1pcs

M:Rattan Chair Left Armrest

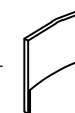

1pcs

B:Rattan Chair Back



1pcs

C:Rattan Chair Base



1pcs

Screw M6x35



6pcs

Screw M6x50



4pcs

Install Tool



1pcs

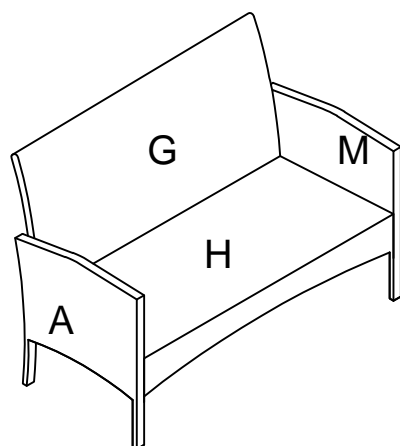

■ 1-Rattan Double Sofa

A:Rattan Sofa Right Armrest



1pcs

M:Rattan Sofa Left Armrest

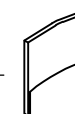

1pcs

G:Rattan Sofa Back

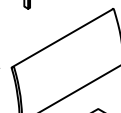

1pcs

H:Rattan Sofa Base



1pcs

Screw M6x35



8pcs

Screw M6x50



4pcs

I: Coffee Table Leg

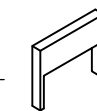

2pcs

J: Coffee table Panel

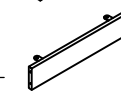

2pcs

K: Glass

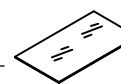

1pcs

Screw M6x35



8pcs

Suction Cup



4pcs

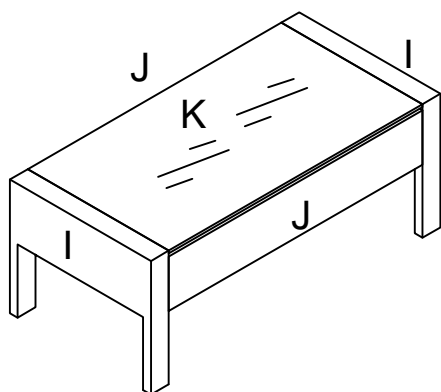

■ 1-Rattan Coffee Table



For successful installation ,When installing,please do not tighten the screws once,When the screws are all installed,a unified tighten all the screws.

Installation step

For successful installation ,When installing,please do not tighten the screws once,When the screws are all installed,a unified tighten all the screws.

■ Single Rattan Chair Installation step

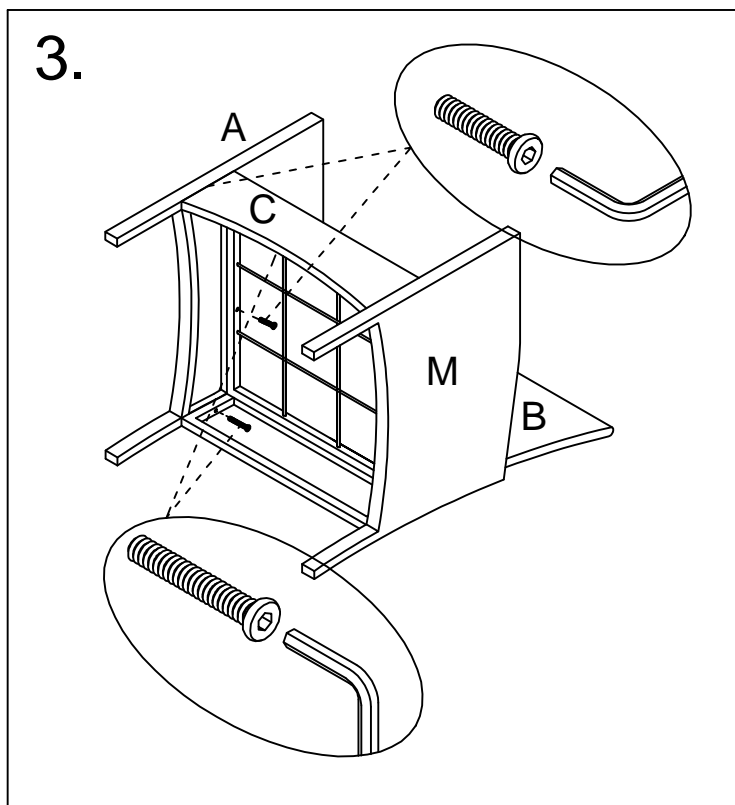
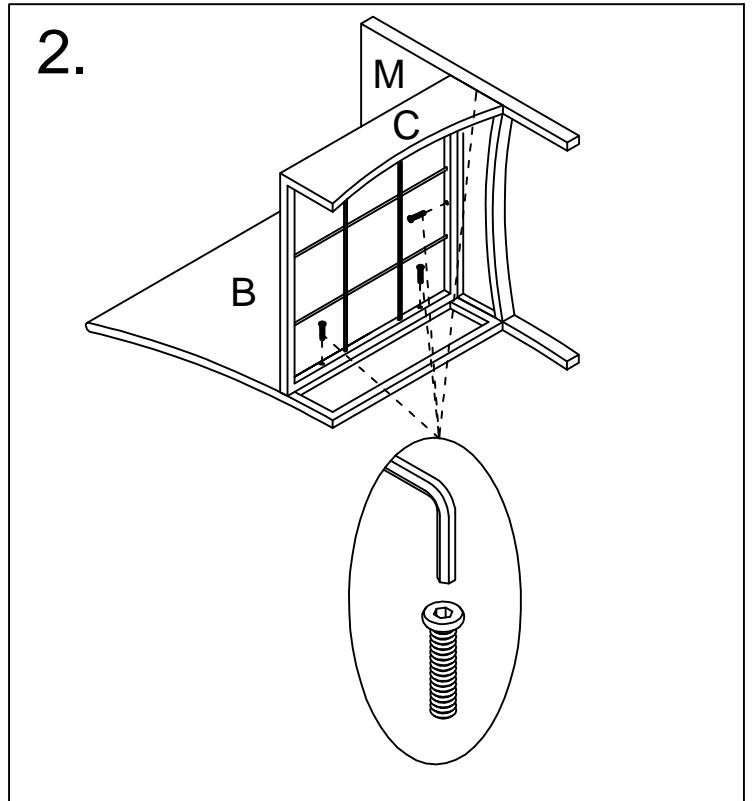
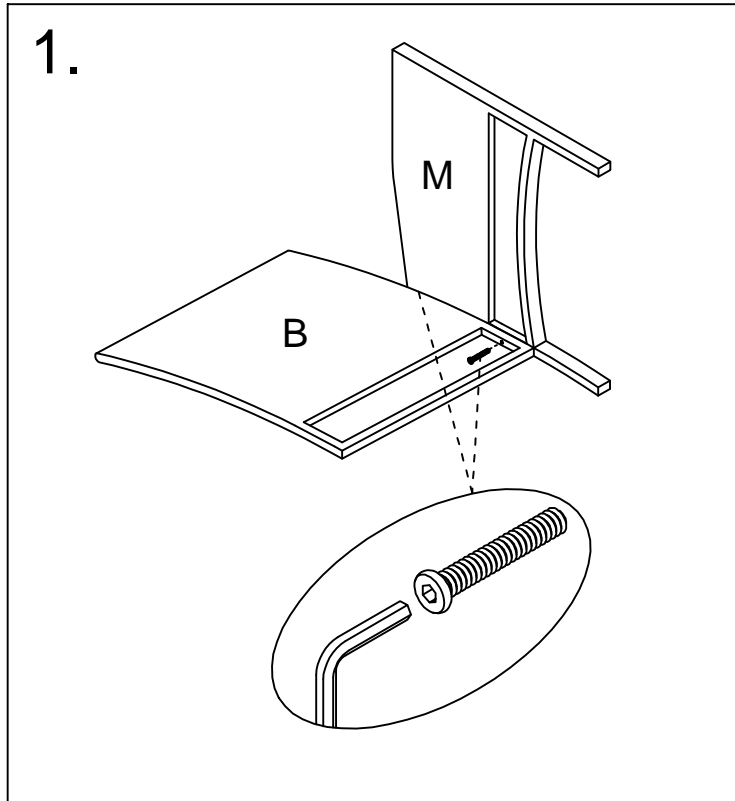

Installation step

For successful installation ,When installing,please do not tighten the screws once,When the screws are all installed,a unified tighten all the screws.

■ Single DOUBLE SOFA Installation step

1.

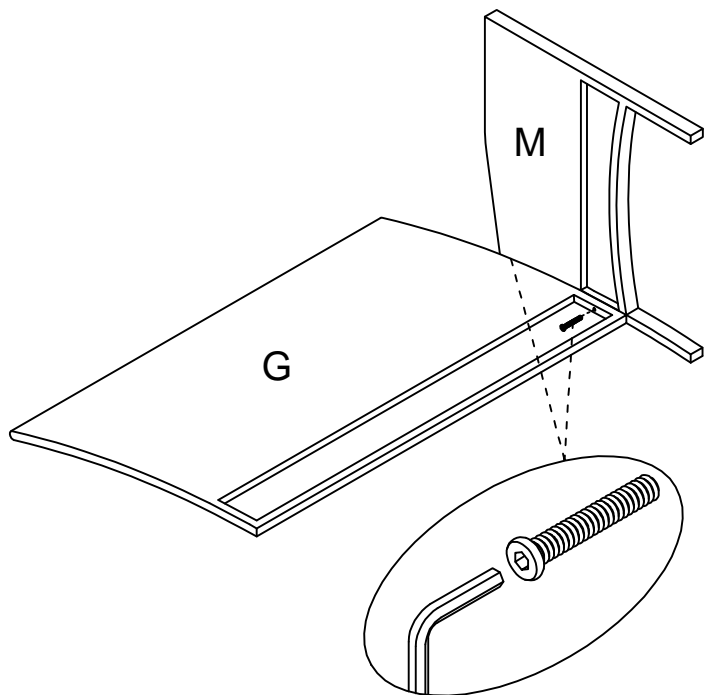

2.

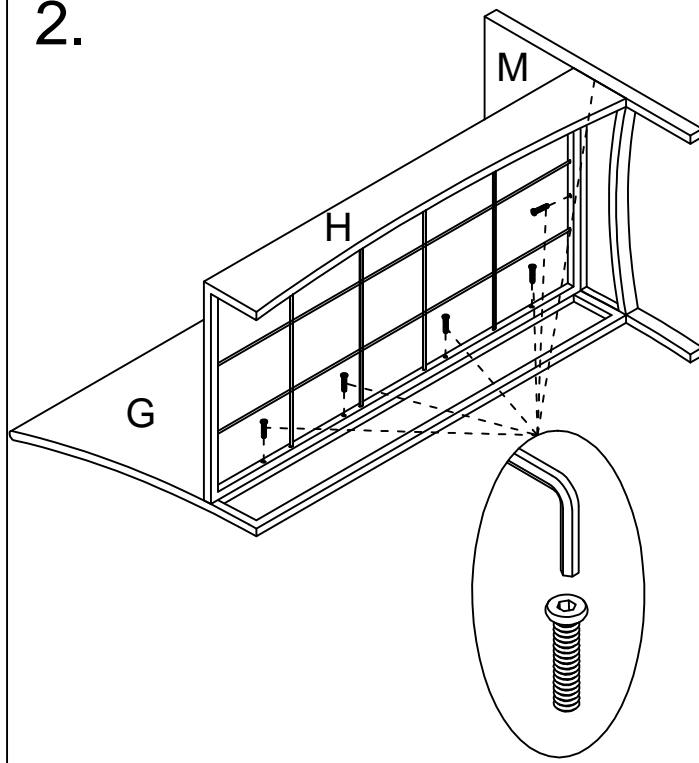

3.

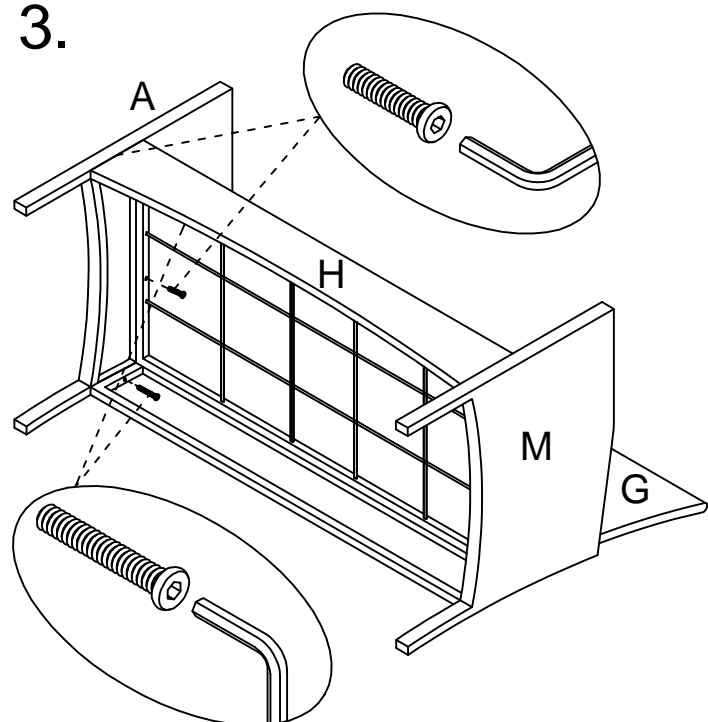

Installation step

For successful installation ,When installing,please do not tighten the screws once,When the screws are all installed,a unified tighten all the screws.

■ Rattan Coffee Table Installation step

1.

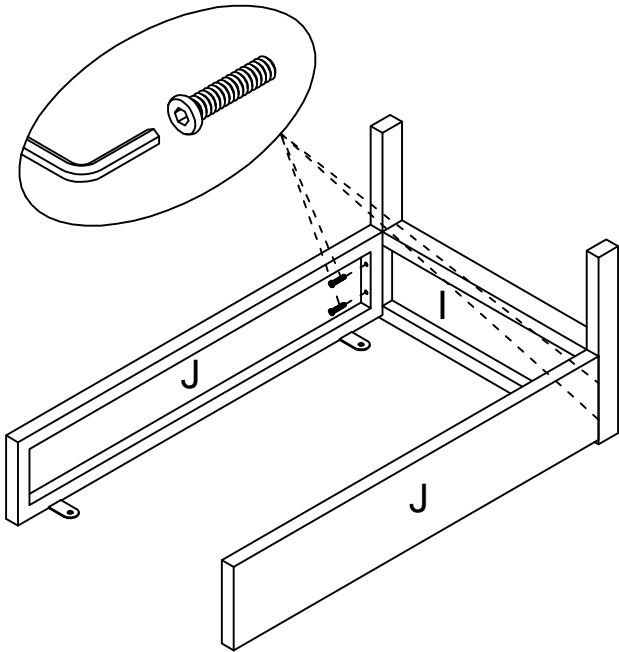

2.

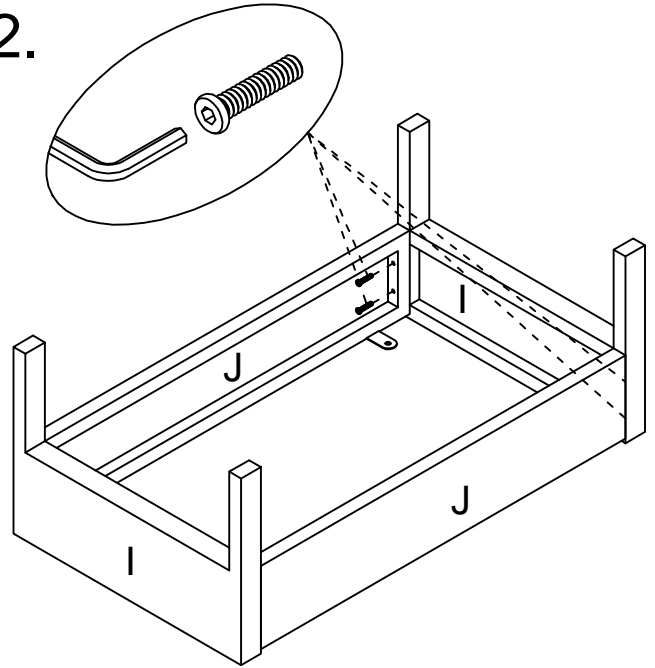

3.

