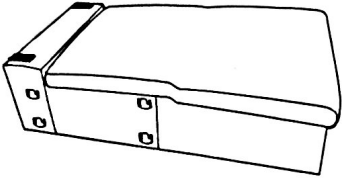
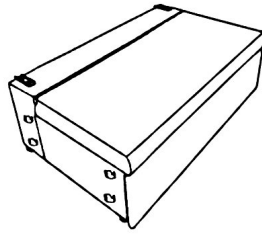
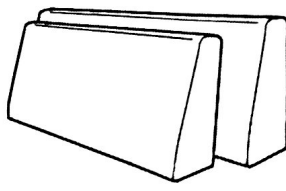
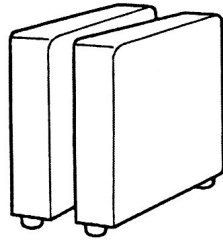
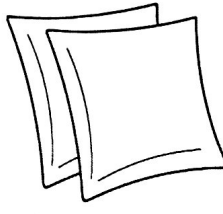
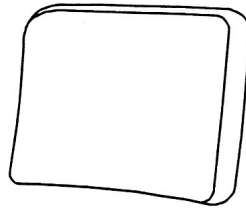
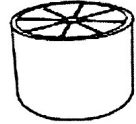
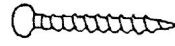
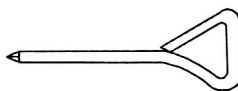

# ASSEMBLY INSTRUCTIONS

## PARTS AND HARDWARE

Have the item assembled located where it will later be used. Make sure no sharp objects such as screws are scattered beneath the assembly area. Lay all parts ready to be used and make sure that all parts are there. It is important to follow every instruction in order to assemble this product in the most efficient way.

### TWO OR MORE PEOPLE REQUIRED FOR ASSEMBLY

A : CHAISE 1 PC	B : LOVESEAT 1 PC	C : BACKREST 2 PCS
		
D : ARM 2 PCS	E : PILLOW 4 PCS	F : BACK CUSHION 3 PCS
		
G : LEG 4 PCS	H : SCREW 4 PCS	I : SPANNER 1 PC
		

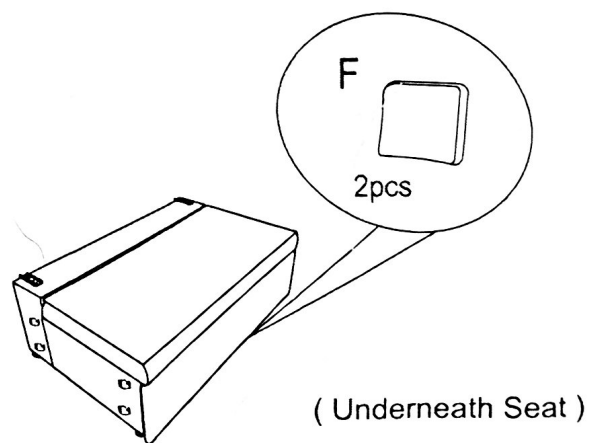
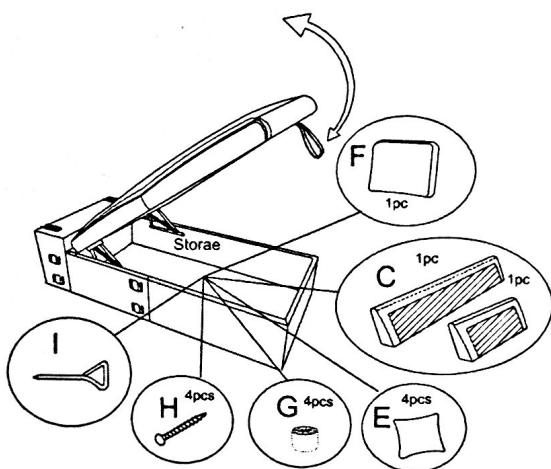

All parts will be found in the storage compartment in the chaise, except two back cushions which will be found under the seat of the loveseat, you may have to turn it upside down to get the two pillows.

# TO HAVE THE CHAISE ON THE RIGHT SIDE FOLLOW THIS PAGE

## Step 1.

Once all parts are taken out of the storage compartment and under the sofa (two pillows), have the chaise upside down and make sure there are no sharp objects underneath. Screw on the legs onto the chaise by locating the white marks underneath showing where the legs should be.

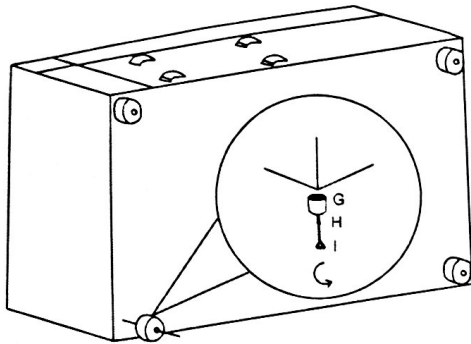

## Step 2.

Place one arm assembling it on the right side, the chaise will have to be lifted up and aligned with all the slots in with the arm as shown in the photo.

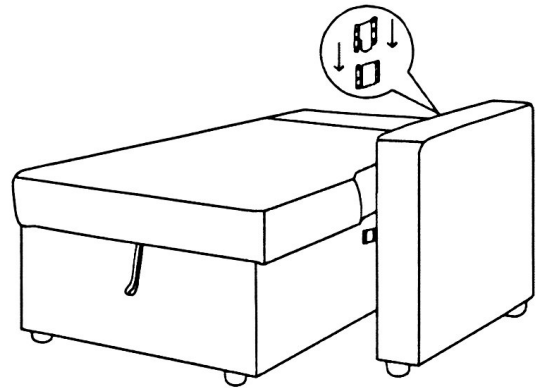

## Step 3.

Have the chaise on the right side and align the metal slots in front of each other, then lift the 2 seater up for the metal slots to connect to the slots on the chaise.

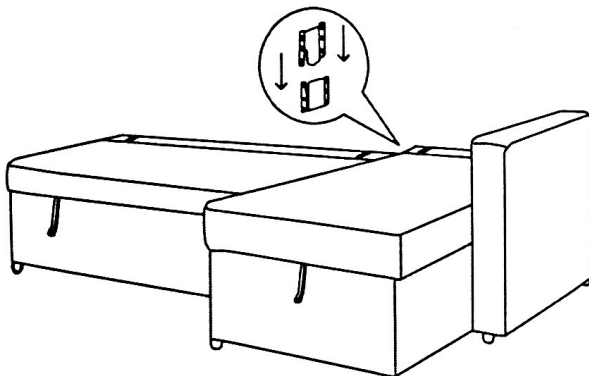

## Step 4.

The backrests have metal slots on the bottom that will go into the slots that are found on the back of the sofa. Once aligned, slide in the back pieces until it is in all the way.

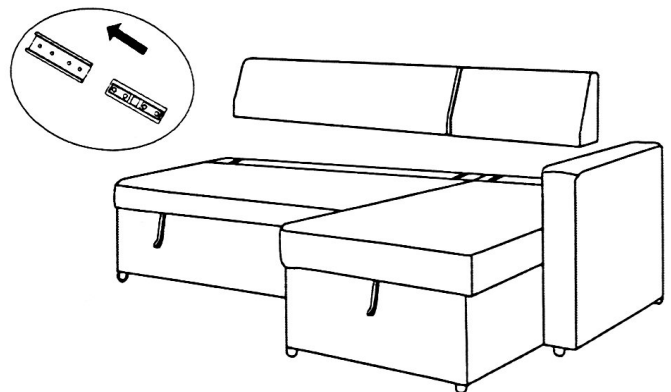

## Step 5.

Place the remaining arm and then attach the back pillows to the back rest. Once completed your sofa is now ready to be used. To pull out the bed component, carefully pull out the bottom part from the love side by pulling on the two straps gently. Lift up the handles at a 45 degree angle and push it down gently until flat. Your chaise storage can be easily lifted up.

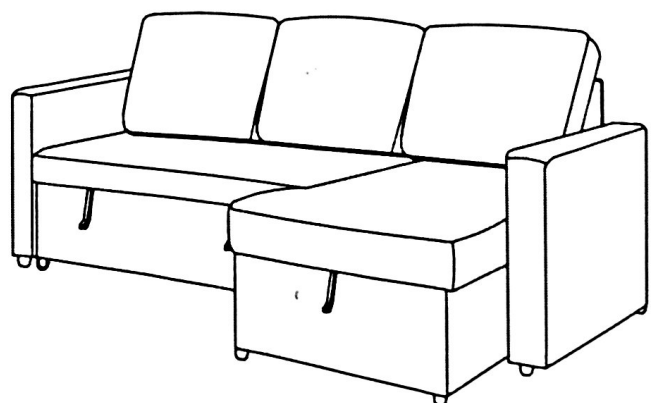
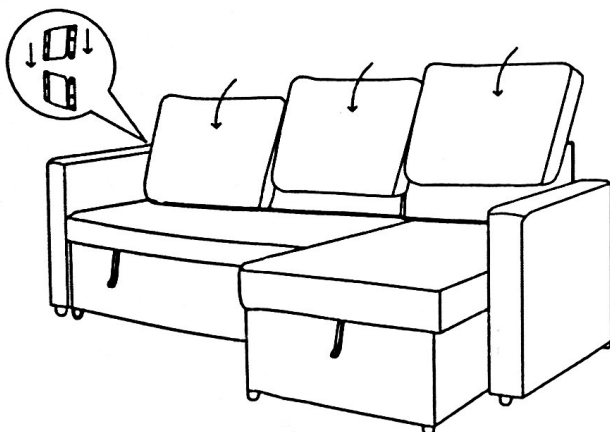

# TO HAVE THE CHAISE ON THE LEFT SIDE FOLLOW THIS PAGE

## Step 1.

Once all parts are taken out of the storage compartment and under the sofa (two pillows), have the chaise upside down and make sure there are no sharp objects underneath. Screw on the legs onto the chaise by locating the white marks underneath showing where the legs should be.

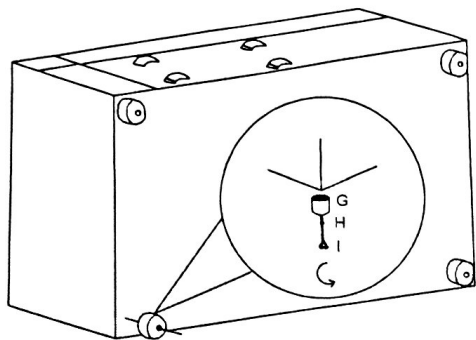

## Step 2.

Place one arm assembling it on the right side, the love will have to be lifted up and aligned with all the slots in with the arm as shown in the photo.

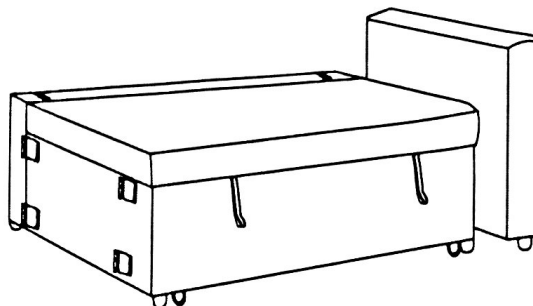

## Step 3.

Have the Chaise on the left side and align the metal slots in front of each other, then lift the chaise up for the metal slots to go onto the ones on the love.

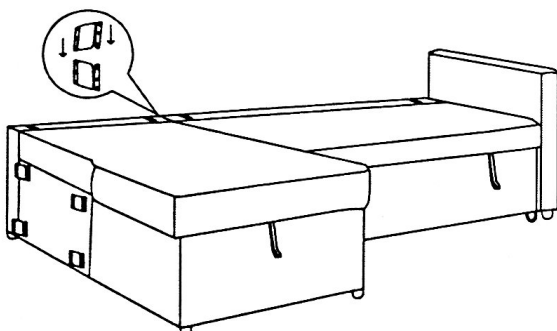

## Step 4.

The backrests have metal slots on the bottom that will go into the slots that are found on the back of the sofa. Once aligned, slide in the back pieces until it is in all the way.

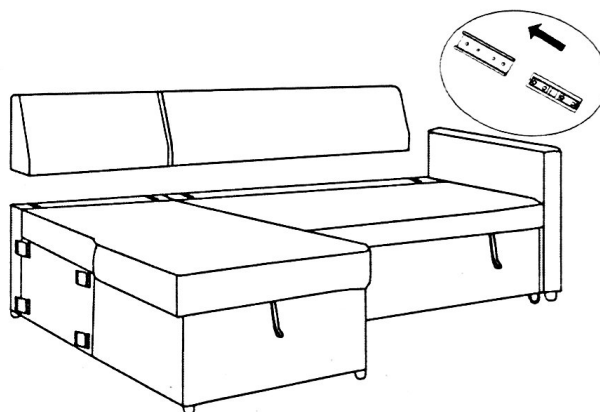

## Step 5.

Place the remaining arm and then attach the back pillows to the back rest. Once completed your sofa is now ready to be used. To pull out the bed component, carefully pull out the bottom part from the love side by pulling on the two straps gently. Lift up the handles at a 45 degree angle and push it down gently until flat. Your chaise storage can be easily lifted up.

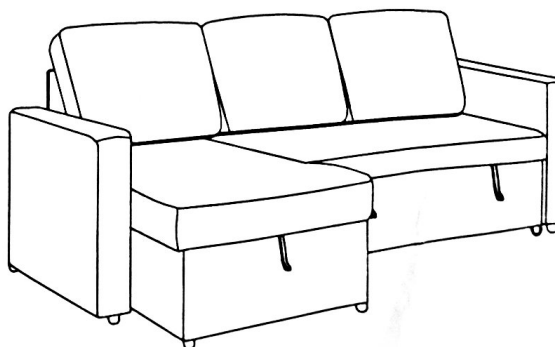
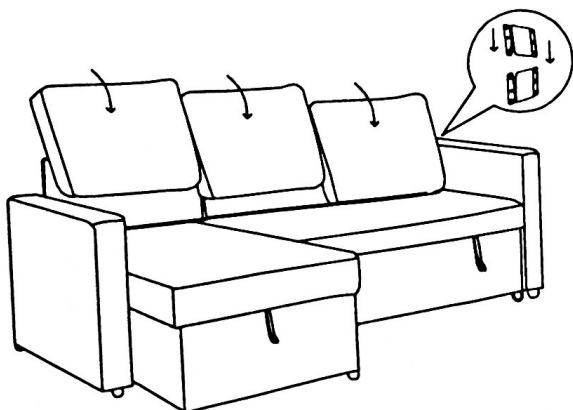

To pull out the bed component, carefully pull out the bottom part from the love side by pulling on the two straps gently. Lift up the handles at a 45 degree angle and push it down gently until flat. Your chaise storage can be easily lifted up.

